

SF



This series includes the models compliant with automotive standards /
Questa serie include i modelli conformi agli standard automotive

BMW	BZ 4009	MB	B8 0138 100 000 001
FCA	075.90.90	Renault	EMZ4.54.700
Ford	W-DX35-62M	VW	39D 848
General Motors	90.25.01		

Fixing half-flanges / Semiflange di fissaggio

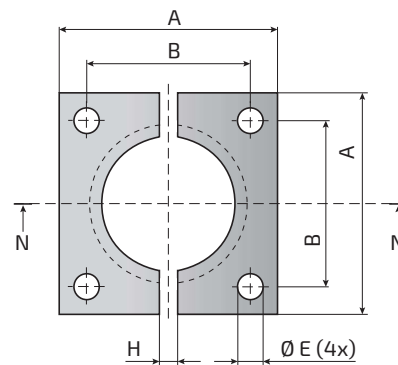
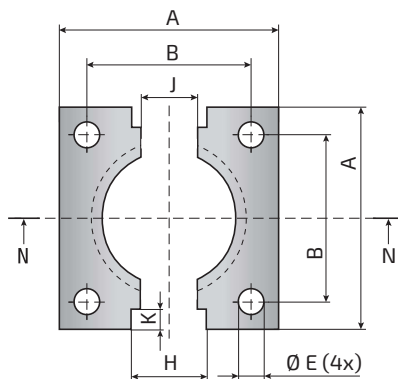
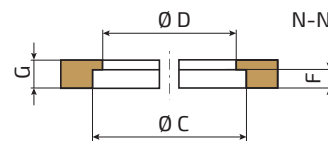
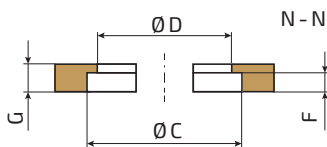

FIG. 1

FIG. 2

Model Modello	Reference to Standards Norme di riferimento	For models... Per modelli...	A mm	B mm	ØC mm	ØD mm	ØE mm	F mm	G mm	H mm	J mm	K mm	FIG.
SF 32	-	AGS350, IGS150, TGS700	50	35	32.5	28.5	6.6	4	7	21	17	6.5	1
38	-	AGS500, IGS250, TGS1000	55	40	38.5	34.5	6.6	4	7	21	17	6.5	1
45	ISO 11901-2, VDI 3003	AGS750, IGS500, LGS500	70	50	45.5	41.5	9	4	7	20	-	-	2
50	ISO 11901-2, VDI 3003	AGS1000, IGS750, TGS2000	75	56.5	50.5	44.5	9	8	12	24	-	-	2
63	-	AGS1500, TGS3000	85	63.5	63.5	57.5	11	8	12	24	-	-	2
63A	ISO 11901-2	AGS1500, TGS3000	100	73.5	64	57	11	8	12	24	-	-	2
75	ISO 11901-2, VDI 3003	AGS2400, IGS1500, TGS5000	100	73.5	75.5	68.5	11	8	12	24	-	-	2
95	ISO 11901-2, VDI 3003	AGS4200, IGS3000, TGS8000	120	92	95.5	88.5	13.5	8	12	24	-	-	2
120	ISO 11901-2, VDI 3003	AGS6600, IGS5000, TGS12000	140	109.5	120.5	113.5	13.5	8	12	24	-	-	2
150	ISO 11901-2, VDI 3003	AGS9500, IGS7500	190	138	150.5	143.5	17.5	8	12	24	-	-	2
195	ISO 11901-2, VDI 3003	AGS20000, IGS10000	210	170	195.5	188	17.5	8	13	24	-	-	2

Fixing possibilities / Fissaggi possibili

