

SWORZNIE TRANSPORTOWE

LIFTING PINS

VDI 3366

STV

Jak zamówić / How to order

Symbol: STV 125

Uwaga / Attention

Ze względów bezpieczeństwa, należy wziąć pod uwagę, że zawsze waga tłoczniaka musi być obsługiwana przez 2 czopy transportowe.
For safety reason, please consider always that the weight of the die has to be supported by 2 lifting pins.

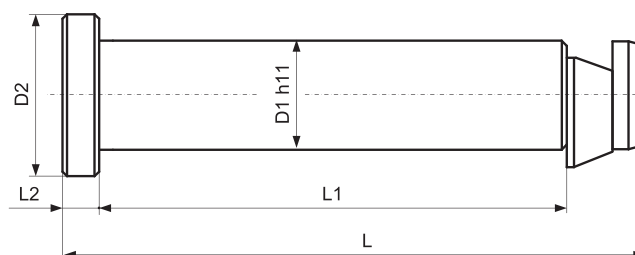
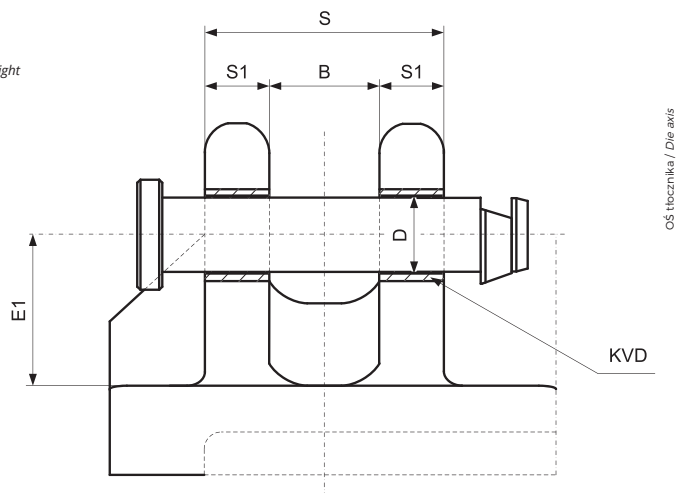

Elementy mocujące złączne transportowe

Symbol	MAX OBCIĄŻENIE MAX LOAD (KG)	MAX WAGA TŁOCZNIKA MAX DIE WEIGHT (KG)	B	D	D1	D2	E1	L	L1	L2	S	S1	MATERIAŁ MATERIAL
STV 32	3200	6400	60	34	32	40	63	175	145	10	140	40	CK45
STV 50	5000	10000	80	42	40	50	80	225	188	10	180	50	CK45
STV 80	8000	16000	100	52	50	60	100	273	230	11	220	60	CK45
STV 125	12500	25000	120	65	63	75	125	347	295	14	280	80	CK45
STV 315	31500	63000	140	78	76	95	160	422	360	15	340	100	42CrMo4 + QT