

UCHWYTY TRANSPORTOWE ZE SWORZNIAMI

LIFTING BRACKETS WITH PINS

UTR

RENAULT

Materiał / Material

CK45
800÷1000 N/mm²

Jak zamówić / How to order

Symbol: UTR 40

Uwaga / Attention

Ze względów bezpieczeństwa, należy wziąć pod uwagę, że zawsze waga tłoczniaka musi być obsługiwana przez 2 uchwyty transportowe. Brak śrub w zestawie, zamów osobno, śruby str. 445
For safety reason, please consider always that the weight of the die has to be supported by just 2 lifting brackets. No screws included, order separately - page 445

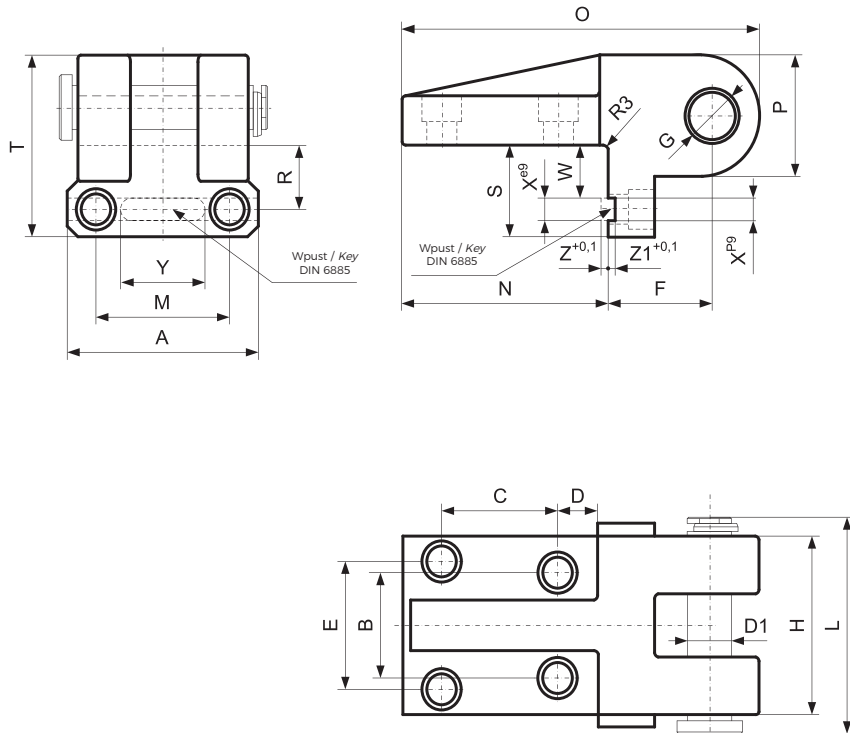

Elementy mocujące złączne transportowe

Symbol	MAX OBCIĄŻENIE MAX LOAD (KG)	MAX WAGA TŁOCZNIKA MAX DIE WEIGHT (KG)	A	B	C	D	D1	E	F	G	H	L
UTR 40	4000	8000	135	56	60	20	32	84	85	33	125	154,0
UTR 63	6300	12600	180	80	70	30	40	110	100	41	160	197,5

Symbol	M	N	O	P	R	S	T	W	X	Y	Z	Z1	ŚRUBY SCREWS DIN 912 8.8
UTR 40	96	100	221	72	30	50	111	24	14	63	4,5	4,5	M16x45
UTR 63	130	125	270	90	35	60	140	27	16	100	5,0	5,0	M20x60