

RE
Pneumatyczny odprowadzacz
wyłoczek
Air scrap remover



RE

Pneumatyczny odprowadzacz wytłoczek / *Air scrap remover*



**WYSOKA ŁADOWNOŚĆ
HIGH LOAD CAPACITY**

**NISKIE ZUŻYCIE POWIETRZA
LOW AIR CONSUMPTION**

PRZYKŁAD ZASTOSOWANIA - APPLICATION EXAMPLE

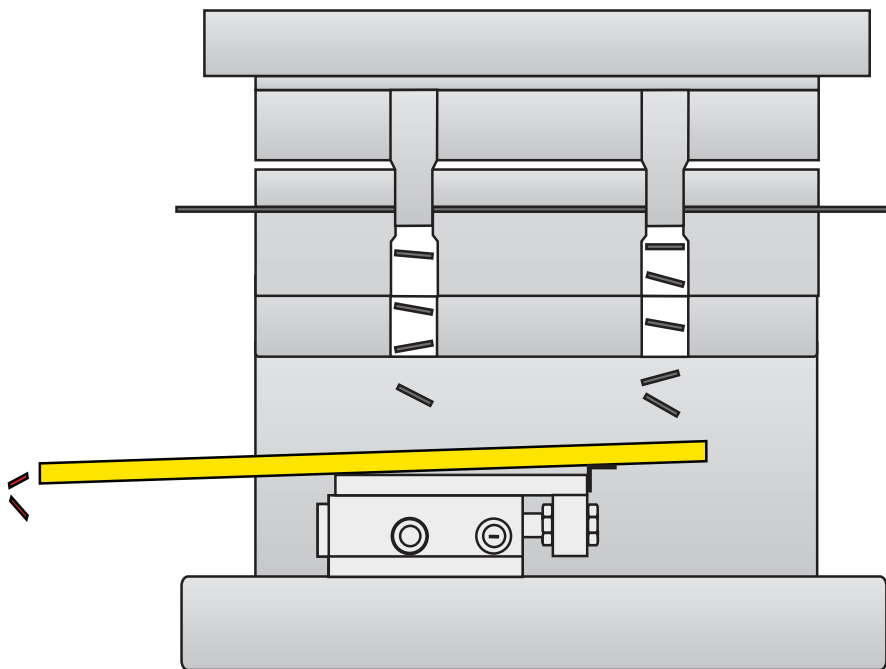

DANE TECHNICZNE - TECHNICAL DATA

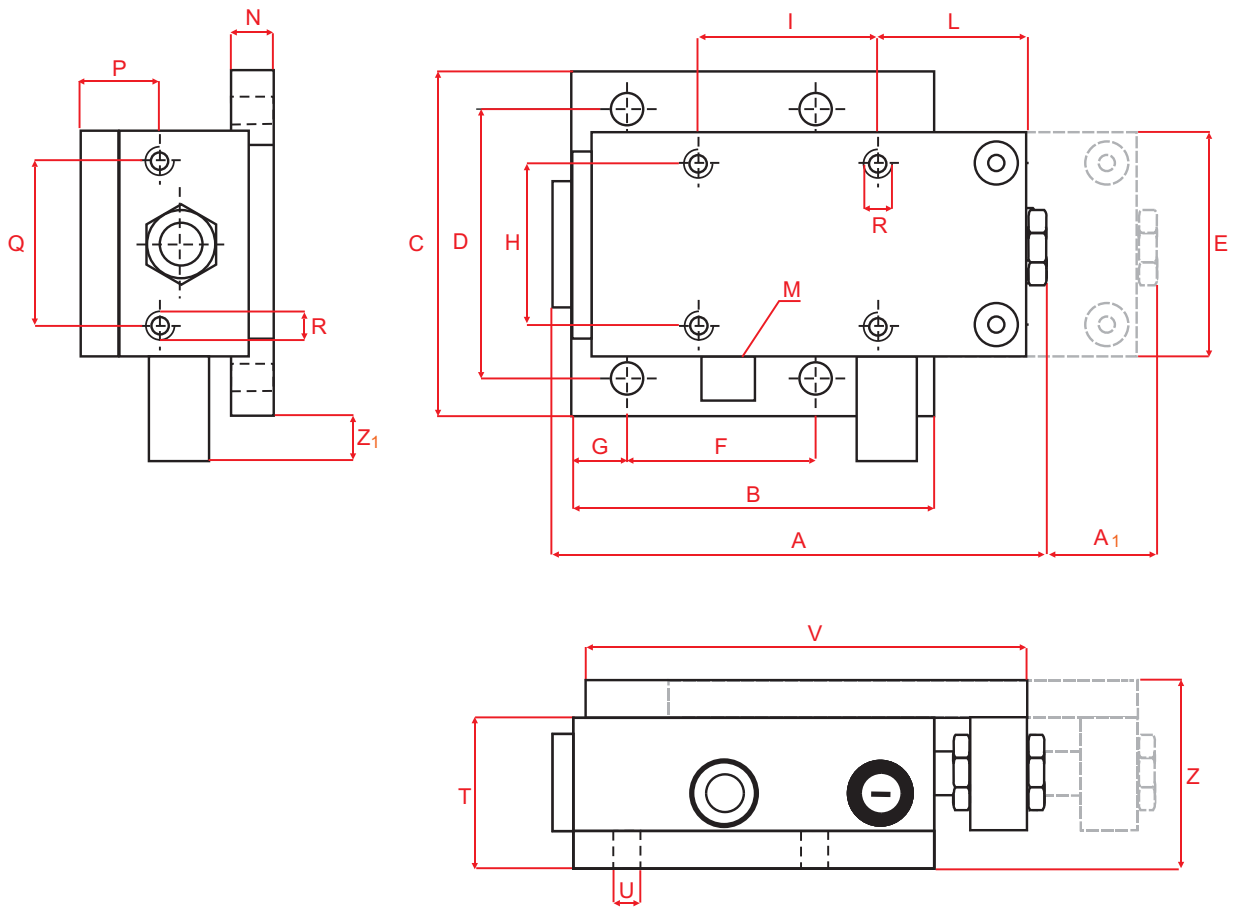

MODEL MODEL	PŁYN FLUID	Ciśnienie pracy Working pressure bar	Minimalne nachylenie Min. mounting inclination	Max. obciążenie Max. load (kg)
RE- 1 RE- 2 RE- 3 RE- 4	Powietrze/air	2/6	5°	10 25 50 80

MODEL MODEL	A	A ₁	B	C	D	E	F	G	H	I	L	M	N	P	Q	R	T	U	V	Z	Z ₁
RE- 1	131	30	95	90	70	60	49	14	25	40	40	1/8"	10	20	40	M6	36	9	120	48	15
RE- 2	158	29	118	100	82	70	60	15	30	50	50	1/4"	12	25	50	M6	53	9	145	65	15
RE- 3	158	33	118	122	104	90	60	15	40	60	60	1/4"	14	25	75	M6	76	9	145	88	18
RE- 4	169	34	130	150	130	110	65	20	50	70	70	3/8"	18	30	80	M6	94	11	157	107	22

Wymiary w mm. - sizes in mm.