

MATRYCE Z WYBIEGIEM STOŻKOWYM

DIES WITH COUNTERSINK RELIEF

MFD

Materiał / Material

HSS - M2*
HWS - A2**
PS (na żądanie / on demand)***

Twardość / Hardness

*60 - 62 HRC
**58 - 60 HRC
***62 - 64 HRC

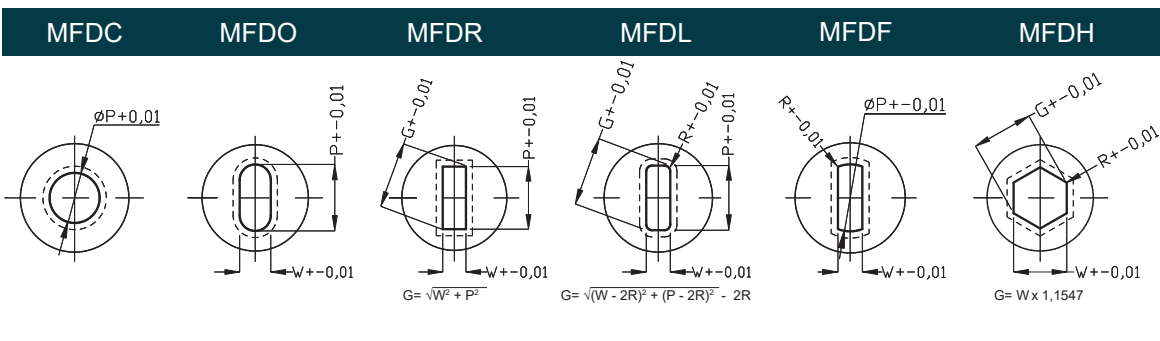
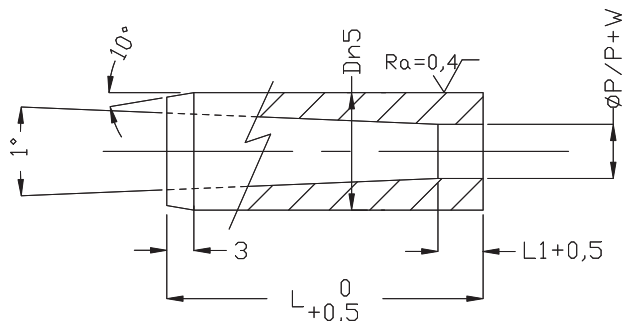

Kształty specjalne dostępne na stronie 238
For qualified shapes see page 238

D1	L1	MAX D3	OKRĄGŁY	KSZTAŁTOWY		DŁUGOŚĆ CAŁKOWITA					
			ZAKRES	MIN	MAX	L					
			RANGE	W	G/P	16	25	25	30	32	35
			P								
5,0	2	2,8	1,0 - 2,4	1,2	2,4	X	X	X	X	X	
6,0	3	3,5	1,6 - 3,0	1,5	3,0	X	X	X	X	X	
8,0	4	4,0	2,0 - 3,5	1,5	3,5	X	X	X	X	X	
10,0	4	5,8	3,0 - 5,0	2,0	5,0	X	X	X	X	X	X
13,0	5	8,0	4,0 - 7,2	3,0	7,2		X	X	X	X	X
16,0	5	9,5	6,0 - 8,8	4,0	8,8		X	X	X	X	X
20,0	8	12,0	7,5 - 11,3	6,0	11,3		X	X	X	X	X
22,0	8	15,0	9,0 - 14,3	8,0	14,3		X	X	X	X	X
25,0	8	17,3	11,0 - 16,6	8,0	16,6		X	X	X	X	X
32,0	8	20,7	15,0 - 20,0	8,0	20,0		X	X	X	X	X
38,0	8	27,7	18,0 - 27,0	10,0	27,0		X	X	X	X	X
40,0	8	27,7	18,0 - 27,0	10,0	27,0		X	X	X	X	X

Jak zamówić / How to order

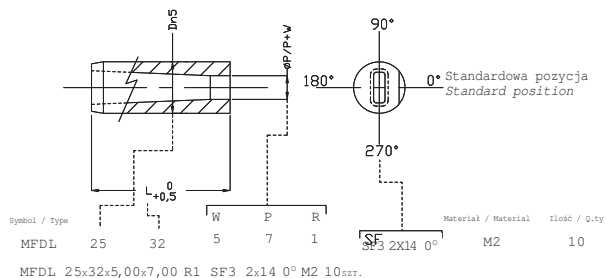

Zmiany w wymiarach standardowych dostępne na stronie 239
For standard alterations see pages 239
Zabezpieczenia przed obrotem dostępne na stronie 241
For flats see page 241
Powłoki oraz dodatkowa obróbka cieplna SHT dostępne na stronie 254
For surface treatments and coatings see page 254

MATRYCE Z WYBIEGIEM STOŻKOWYM

DIES WITH COUNTERSINK RELIEF

MFD

Materiał / Material

HSS - M2*
HWS - A2**
PS (na żądanie / on demand)***

Twardość / Hardness

*60 - 62 HRC
**58 - 60 HRC
***62 - 64 HRC

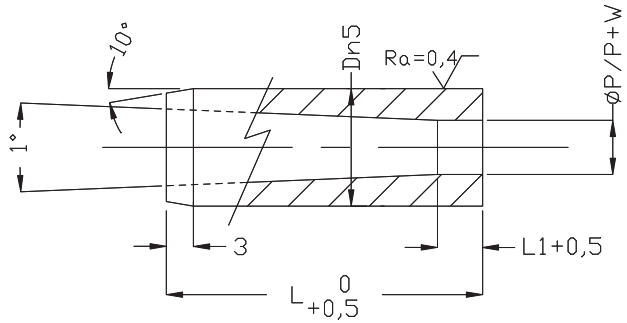

MFDC MFDO MFDR MFDL MFDF MFDH

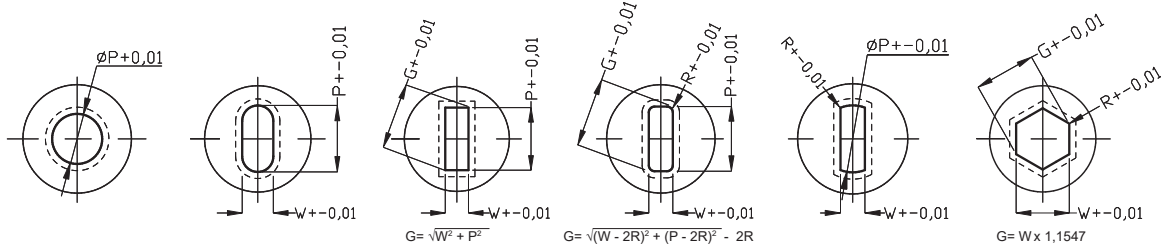

Kształty specjalne dostępne na stronie 238
For qualified shapes see page 238

D1	L1	MAX D3	OKRĄGŁY	KSZTAŁTOWY		DŁUGOŚĆ CAŁKOWITA						
			ROUND	SHAPE		OVERALL LENGTH						
			ZAKRES RANGE P	MIN W	MAX G/P	20	25	30	32	35	40	45
450	8	36,0	19,05 - 35,6	5,0	35,6	X	X	X	X	X	X	X
500	8	41,0	22,2 - 40,6	7,0	40,6	X	X	X	X	X	X	X
560	8	46,0	25,4 - 45,6	8,0	45,6	X	X	X	X	X	X	X
630	8	51,0	28,55 - 50,5	9,0	50,5	X	X	X	X	X	X	X
710	8	57,0	31,75 - 56,5	11,0	56,5	X	X	X	X	X	X	X
760	8	61,0	34,90 - 60,5	13,0	60,5	X	X	X	X	X	X	X
850	8	67,0	42,50 - 66,5	15,0	66,5	X	X	X	X	X	X	X
900	8	71,0	44,5 - 70,5	20,0	70,5	X	X	X	X	X	X	X
1000	8	79,0	49,5 - 78,5	25,0	78,5	X	X	X	X	X	X	X

Jak zamówić / How to order

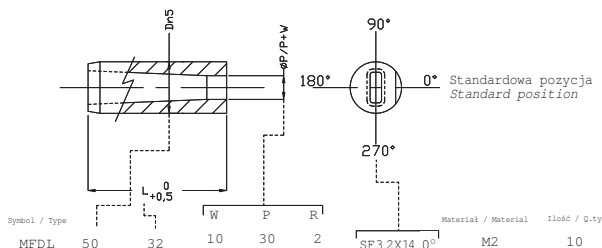

MFDL 50x32x10,00x30,00 R2 SF3 2x14 0° M2 10szr.

Zmiany w wymiarach standardowych dostępne na stronie 239
For standard alterations see pages 239
Zabezpieczenia przed obrotem dostępne na stronie 241
For flats see page 241
Powłoki oraz dodatkowa obróbka cieplna SHT dostępne na stronie 254
For surface treatments and coatings see page 254