

# STEMPLE SZYBKOWYMIENNE DO WYSOKICH OBCIĄŻEŃ Z ODKLEJACZEM

# MBHE

BALL LOCK HEAVY DUTY EJECTOR PUNCHES

Materiał / Material

HSS - M2

Twardość / Hardness

60 - 62 HRC

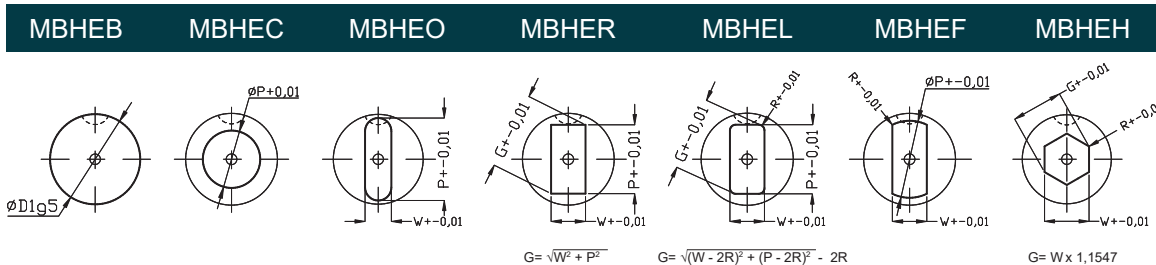
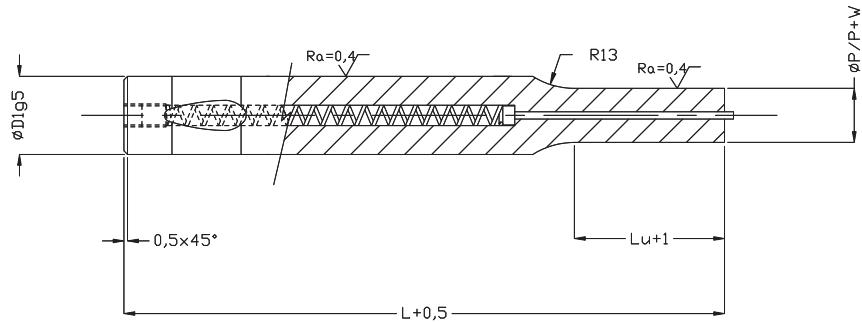

Kształty specjalne dostępne na stronie 238  
For qualified shapes see page 238

D1	Lu	OKRĄGŁY	KSZTAŁTOWY		DŁUGOŚĆ CAŁKOWITA					
		ZAKRES	MIN	MAX	L					
		RANGE	W	G/P	63	71	80	90	100	125
		P								
10,0	13/19	2.5 - 9.98	2.5	9.98	X	X	X	X	X	X
13,0	13/19	5.0 - 12.98	4.5	12.98	X	X	X	X	X	X
16,0	19/25	8.0 - 15.98	6.0	15.98	X	X	X	X	X	X
20,0	19/25	12.0 - 19.98	8.0	19.98	X	X	X	X	X	X
25,0	19/25	16.0 - 24.98	10.0	24.98	X	X	X	X	X	X
32,0	19/25	24.0 - 31.98	12.0	31.98		X	X	X	X	X
40,0	19/25	30.0 - 39.98	18.0	39.98			X	X	X	X

Zmiany w wymiarach standardowych dostępne na stronie 239  
For standard alterations see pages 239  
Powłoki oraz dodatkowa obróbka cieplna SHT dostępne na stronie 254  
For surface treatments and coatings see page 254

Jak zamówić / How to order

